

SAMPLE QUESTION PAPER
SOCIOLOGY

Higher Secondary



Sociology



Guidelines for the preparation of question paper

1. Question paper may be prepared in accordance with the design and blue print so as to ensure fair distribution of Curriculum Objectives/ content areas and types of questions.
2. Question should be based on the Curriculum Objectives.
3. Curriculum Objectives can be clubbed or can be split into shorter chunks, whenever necessary, for framing questions.
4. Questions for assessing higher order mental processes should be framed, focusing on the ability to apply, analyse, evaluate and think creatively.
5. Different types of questions - objective type, short answer type, essay type etc., shall be included in the question paper.
6. There need not be separate sections in the question paper for different types of questions.
7. Questions that test mere recalling and rote learning shall be avoided.
8. A fair distribution of open-ended questions shall be included to promote divergent and creative thinking.
9. Question texts and the directions given shall be simple, clear and comprehensive.
10. Objective type questions should aim at testing higher order mental processes.
11. There shall not be a rigid pattern regarding the type of questions, number of questions and order of questions.
12. Questions shall be life-related
13. Questions shall be in accordance with the learning activities.
14. Care shall be taken to avoid gender bias, communal sentiments etc. in the questions framed.
15. Adequate hints for answering the questions shall be given, wherever necessary.
16. Choice of questions may be given only upto a maximum of 20% of the total score. While giving the choice, due attention shall be given to select the same content area/ curriculum objective, scores, mental processes involved etc.
17. The duration of the examination will be 2 hrs for subjects having 60 scores and 2½ hrs for those having 80 scores, in addition to the *cool off time* for 15 mts.
18. Question paper shall be bilingual (English and Malayalam) except in languages. Technical terms

can be transliterated wherever necessary.

19. Scores for objective type questions shall not exceed 20% of the total score.
20. Maximum score for a question shall not exceed 10% of the total score. However in Botany and Zoology a maximum of 5 score can be given to a question. Fractions may be avoided.
21. All questions should have an entry level, so that all learners who have undergone the learning process can get the minimum score. However, the possibility of applying higher order mental process, considering the different levels of the learners shall be taken into account.
22. Score should be noted in the question paper against each question and word limit may be specified wherever necessary.
23. Score shall be given to a question in accordance with the mental processes involved in answering it.
24. The possibility of using a single question text as the question text for other questions can be explored.
25. While setting a question paper, the time allocation shall be in accordance with the time for reading the questions and thinking, planning and writing time of the answer.



Guidelines for Scoring key-Sociology

1. Scoring indicators should reflect the mental processes involved in answering that question.
2. Concepts to be evaluated should be clear and specific.
3. Scoring key for open-ended questions shall give due consideration to a fairly wide range of possible responses. It may include sequencing of ideas, relevance, originality, creativity, level of thinking, presentation etc.
4. The scoring key should indicate the split up scores for the essential lower order mental processes and the higher order mental processes involved in the answer.
5. Reasonable split up may be given for the scores.
6. While evaluating the ability to express the knowledge constructed by the learner, limitations in language shall be ignored.



Mental Process- Sociology

- 1 Retrieves/recollects /retells information
- 2 Readily makes connections to new information based on past experience and formulates initial ideas/ concepts.
- 3 Detects similarities and differences
- 4 Classifies/categories/ organises information appropriately
- 5 Translates/ Transfer knowledge/ understanding and applies them in new situations
- 6 Establishes cause- effect relationship
- 7 Makes connection/ relates prior knowledge to new information/applies reasoning and draw inferences.
- 8 Communicates knowledge/understanding through different media
- 9 Imagines/ fantasises/designs/predicts based on received information.
- 10 Judges/appraises/evaluates the merits or demerits of an idea/ develops own solutions to a problem.



Curricular Objectives- Sociology

CURRICULUM OBJECTIVES

1. To develop awareness about the distinctive nature of Indian social system through discussion debate etc., on the socio - cultural characteristics of Indian society and to prepare a report.
2. To become aware of the unity and diversity of Indian society through role play, discussion , debate etc., on the factors which indicate the social and cultural heterogeneity of India and to present an observation report.
3. To generate a favourable attitude towards the factors of unity of Indian society through role play, discussion, debate etc. on the destabilizing forces that threaten the national unity and integrity and to present a report.
4. To identify ethnic problems and suggest suitable remedial measures through group discussion on ethnicity , ethnic problems and causes of ethnic problems in India and to prepare a report.
5. To create a sense of tolerance towards various religions by visiting different religious / pilgrim centers, book review, showing audio - visual aids etc., and to reflect the major Indian religions , their values and norms and to prepare an album.
6. To generate a favourable attitude towards the linguistic diversity of Indian society through discussion, role play, chart presentation, etc., on the development and classification of Indian languages and prepare a chart.
7. To develop awareness about the evolution of Indian Social life upto Indus Valley Civilization, through a visit to historically important places, discussion seminar etc., on the features of Indian society in the ancient period and Indus Valley Civilization and to present a report.
8. To identify the major features of Indian society during the Vedic period through discussion, seminar, debate etc. and to list the changes.
9. To acquaint with the strong holds of Indian social life through discussion, review of literature, narrating stories etc., on Varnashrama system and Purusharthas and to prepare an assignment.
10. To differentiate Indian social life during Buddhist and Islamic periods through discussion, debate etc., on the Buddhist and Islamic traditions, their impact and to prepare an album.
11. To evaluate the changes in Indian society due to the British administration through discussion, debate and seminar on the nature of Indian society at the time of British intrusion and the impact of British administration.

12. To differentiate between rural and urban communities through field visit, observation chart presentation etc. for observing the features of rural and urban communities and to prepare a chart showing the differences.
13. To analyse the urban problems and recommend remedial measures on the basis of the urban visit, group discussion etc, and to present a report.
14. To identify and recognise the major changes occurred in Indian villages by comparing its features during the ancient, medieval and modern periods through review of relevant articles and reference books, content analysis, discussion and collect pictures and prepare an album.
15. To develop the skill to identify the process of urbanisation through debate, discussion etc., on the concept of urbanisation, urbanity and urbanism and to arrange a poster exhibition.
16. To identify and differentiate the types and forms of marriage through observing different marriage ceremonies, referring periodicals, discussion, etc., and to prepare an album / report.
17. To equip the students to take up responsibilities and discharge their duties as member of the family through discussion, review of literature and observation of different types of families and their functions and to prepare an album.
18. To equip the students to identify and differentiate nuclear, extended and joint families through survey, discussion, observation, debate, etc., and present a report.
19. To equip the students to accept and follow the various rules of marriage through discussion, seminar, review of literature etc., on the rules of marriage and prepare an assignment.
20. To recognise the changes happening in the marriage and family relations through visit to old age homes, day care centers, discussion, etc., and conduct a seminar.
21. To familiarise the concept of kinship and related terminologies and recognise its importance through discussion, seminar, instant presentation, etc., and to prepare a genealogical chart / kinship tree.
22. To identify kinship usages and recognise their importance in social life through discussion, seminar, chart presentation etc. and prepare a booklet of kinship usages.
23. To identify and differentiate different Varnas and Castes existing in Indian society through discussion and social survey on the features of Varna and Caste and to prepare a report.
24. To differentiate the peculiarities of Caste and Class through analysing the data collected and conducting brain storming and instant presentation to find out continuum between Caste and Class and to prepare a report / chart.
25. To become aware of the evil effects of caste system through collage presentation, and discussion on untouchability with special reference to Kerala and to prepare an album.
26. To analyse the significance of caste in the contemporary society through a panel discussion on
27. To analyse the present position of Scheduled Castes through survey and discussion on their problems and welfare measures and to prepare report / magazine with suitable suggestions.
28. To analyse the present socio - economic conditions of Scheduled Tribes through tribal visit and observation on their peculiarities, problems and welfare measures and to prepare an album /

report.

29. To identify Other Backward Classes, and to recognize the significance of different commissions in their upliftment through an interaction with officials, discussion, etc., and to present a report.
30. To recognize the importance of Backward Class Movements in the upliftment of the Other Backward Classes through discussion, seminar etc., on various Backward Class Movements and to prepare a report showing their contemporary relevance.
31. To develop the concept of social movements and recognize their relevance in eliminating social evils and bringing about a desirable change in the society through role play, poster making discussion etc., of various socio religious reform movements and to prepare a report / magazine.
32. To appreciate Gandhiji as a social reformer through discussion, debate book review, poster making, etc., on the basis of his ideologies, contributions and his role in National Movement and to arrange a poster exhibition.
33. To realise the sociological implications of freedom movement through sharing of experiences with freedom fighters, reading their biographies / auto biographies and interviewing the predecessors of freedom fighters and to present a report.
34. To analyse and compare tribal movement in the pre and post independence periods through field trip, discussion, book review, etc., and to prepare an album / collage / scrap book with special reference to Kerala.
35. To identify the contemporary tribal movements in the country and evaluate the demands for the formation of new states through discussion, seminar review of literature, etc., in the light of the Naxalbari and Jharkhand Movements and to write an assignment.
36. To recognize the importance of population composition by analysing the population of India through discussion, magazine work, seminar, etc., and to prepare a report / diagrammatic representation.
37. To predict the effects of over population through discussion, instant presentaion, etc., on population explosion and to arrange a poster exhibition / diagrammatic representation and suggest possible remedies
38. To analyse the impact of fertility, mortality and morbidity on population through discussion, diagrammatic representation, and to collect data and prepare diagrams showing the factors affecting population explosion in India and in Kerala.
39. To recognize the inevitability of population policy and its successful implementation in controlling over population through discussion, book review and evaluation survey and to prepare report with possible suggestions.
40. To realise industrialisation as a structural process of social change and to analyse the impact of industrialisation through an industrial area visit, discussion etc., and to present a report containing process of industrialisation its consequences and problems.
41. To analyse the impact of urbanisation and modernisation through urban area visit debate, seminar, etc., and prepare an assignment showing its social impacts.
42. To identify the castes and communities that have improved their status due to the cultural processes of social change by familiarising Sanskritisation and Westernisation, through observation discussion, debate etc., and to present a report / chart.

-
43. To realise the importance of education in the process of social change through discussion, seminar, interview and present a seminar report.
 44. To recognise the importance of planning in social change through the visit to (panchayat / block office) and prepare a plan of action.
 45. To identify and analyse the social problems through discussion / field visit etc., and prepare a wall magazine / review report.
 46. To realize the causes and to predict the consequences of illiteracy through the analysis of census report, discussion, seminar, role play and to prepare a report / the diagrammatic representation of data.
 47. To analyse and evaluate the impacts of poverty and unemployment through discussion, seminar, field visit (Block Development Office, / Panchayat Office, etc.,) and prepare a chart showing the governmental interventions (programmes).
 48. To analyse alarming nature of the problem of crime and Juvenile delinquency and its corrective measures through group discussion, visit to police station, Juvenile home, etc., and prepare a report / diagrammatic representation
 49. To identify prostitution as a social evil and suggest measures for the rehabilitation of the victims of prostitution through discussion, slide show, etc., and to prepare an assignment analysing the causes and consequences of this social evil.
 50. To identify and compare the status of women in different periods of history through discussion, debate etc., and preparation of an assignment / report.
 51. To develop a sense of 'gender equality' through opinion survey, debate, discussion etc. on the concept of gender and gender issues and to prepare a report.
 52. To assess the role of institutions in the perpetuation of gender discrimination through social survey, content analysis, opinion survey etc., on the role played by family religion, caste system and mass media and submit a report.
 53. To suggest suitable measures to improve the status of women through seminar, discussion content analysis etc., on the issues and problem related to them and to present a collage / report.
 54. To develop a sense of 'National Sentiment through discussion, collection, power point presentation etc. on the concepts National integration, Nationalism, Nationality and prepare a report / album.
 55. To develop the skill to overcome the hinderance to National integration through discussion, seminar, content analysis etc. on the hurdles to National integration and to prepare a scrap book / report / Collage.



Design of the test- Sociology

WEIGHTAGE TO CONTENT/ OBJECT

Sl.No.	Unit/CO	CO	Score	% Score
1	The Indian society	6	4	5
2	Evolution of Indian society	7,6,10	3	4
3	Rural - Urban Communities	13,15	5	6
4	Social Institution in India	16,20,21,22	9	11
5	Caste system	25,26	5	6
6	Backward classes	27,28,29	(8)	(10)
7	Social Movements	31,32,33,34	6	8
8	Population in India	36,37,38,39	16	19
9	Social change in India	40,41,42	9	11
10	Social problems in India	45,46,48	6	8
11	Women and Society	50,51,52	13	16
12	National Integration	54,55	5	6

WEIGHTAGE TO TYPES OF QUESTIONS

Sl.No.	Type of Questions	No. of Questions	Score	% Score
1	Objective	14	14	18
2	Short answer	12(1)	46(5)	57
3	Essay	3(1)	20(8)	25
	Total		80	100

* Score given in bracket is the score for the questions of internal choice.

BLUEPRINT

Sl.No	Unit/ CO	Type of questions							
		Objective		Short Answer		Essay		Total	
		Number Questions	Score	Number Questions	Score	Number Questions	Score	Number Questions	Score
1	6	1	1	1	3				4
2	7,9,10	3	3						3
3	13,15	1	1	1	4				5
4	16,20,21,22	1	1	2					9
5	25,26			1	5				5
6	27,28,29					(1)	(8)		(8)
7	31,32,33,34	2	2	1	4				6
8	36,37,38,39	2	2	2	5	1	8		15
9	40,41,42	1	1			1	8		9
10	45,46,48	1	1	1	5				6
11	50,51,52,53	1	1	2(1)	8(5)	1	4		13(5)
12	54,55	1	1	1	4				5
	Total		14		46		20		80

* Score and number of questions given in the bracket is the score and number of questions of internal choice.

**HIGHER SECONDARY EXAMINATION
SAMPLE QUESTION PAPER**

SOCIOLOGY

Std. XII

Total Score : 80
Time : 2 1/2 Hrs

INSTRUCTIONS

- 1 Read questions carefully before answering the questions.
- 2 Calculations, figures and graphs should be shown in the answer sheet itself
- 3 All the questions are compulsory and only internal choices are allowed.
- 4 When you select a question, all the sub questions must be answered from the same question itself.
- 5 Maximum time allowed is 2 hours 45 minutes, including cool off time.
- 6 First 15 minute is cool off time during which you should not answer the questions. This time is meant to read the questions carefully.

Choose appropriate answer from bracket

1. Raju travels across India. When he reaches Tamil Nadu he hears people speaking Tamil, at Karnataka people speak Kannada and in Maharashtra they speak Marathi. What do you understand from this about the nature of Indian society.

രാജു ഇന്ത്യയിലുടനീളം സഞ്ചരിച്ചപ്പോൾ തമിഴ്നാട്ടിലുള്ളവർ തമിഴ് സംസാരിക്കുന്നതും കർണാടകയിൽ ഉള്ളവർ കന്നട സംസാരിക്കുന്നതും മഹാരാഷ്ട്രയിൽ ഉള്ളവർ മറാത്തി സംസാരിക്കുന്നതും കണ്ടു. ഇതിൽ നിന്നും ഇന്ത്യൻ സമൂഹത്തിന്റെ എന്ത് പ്രത്യേകതയാണ് മനസ്സിലാക്കുന്നത്.

- a. Cultural diversity
- b. Linguistic diversity
- c. Geographical diversity
- d. Religious diversity

- 2 The streets, lanes and bylines were arranged symmetrically.

- There was an excellent drainage system
- There was a collage, large granary, a multipillared assembly hall and a public bath.

Given below are certain features Indus Valley Civilization. By analysing these features what do you derive at.

ഭംഗിയായി ക്രമീകരിച്ച തെരുവുകൾ, നിരത്തുകൾ, കുറ്റമറ്റ അഴുക്ക് ചാലുകൾ, കോളേജ്, ധാന്യക്കലവറ അനേകം തൂണുകളുള്ള അസംബ്ലിഹാൾ, പൊതുസ്നാനഘട്ടം മുതലായവ സിന്ധു നദീതട സംസ്കാരത്തിന്റെ സവിശേഷതകളാണ്. ഇവ അപഗ്രഥിക്കുമ്പോൾ നിങ്ങൾ എന്ത് അനുമാനത്തിലാണ് എത്തിച്ചേരുന്നത്.

- a. It was an Urban Civilization

- b. It was a rural Civilization
- c. It was a semi - rural Civilization
- d. It was a metropolitan Civilization

3. The age of 55 is the retirement age of government servants of Kerala. Similarly during vedic period the life span of an individual was divided into four stages .Of these, which stage is similar to the retirement age of the Government servant.

കേരളത്തിലെ ഒരു സർക്കാർ ഉദ്യോഗസ്ഥന്റെ പെൻഷൻ പ്രായം 55 വയസ്സാണ്. വേദകാലഘട്ടത്തിൽ ഒരു വ്യക്തിയുടെ ജീവിത കാലയളവിനെ നാല് ഘട്ടങ്ങളായി തിരിച്ചിരിക്കുന്നു. ഇതിൽ ഏത് ഘട്ടമാണ് സർക്കാർ ഉദ്യോഗസ്ഥന്റെ റിട്ടയർമെന്റ് കാലയളവിന് സമാനമായിരിക്കുന്നത്.

1

- a. Brahmacharya
- b. Grihastha
- c. Vanaprastha
- d. Sanyasa

4. You have visited your friend Ramu's house and was talking with him and his wife. After a few minutes, Ramu's father entered the house. Immediately Ramu's wife ran inside. Later you asked about this incidence. Ramu replies that it is their custom. Usually father - in - law and daughter - in - law do not sit together. What type of practice is this.

നിങ്ങളുടെ സുഹൃത്ത് രാമുവിന്റെ വീട്ടിൽ വെച്ച് നിങ്ങൾ രാമുവും ഭാര്യയുമായി സംസാരിച്ചിരിക്കേ, രാമുവിന്റെ അച്ഛൻ അവിടേക്ക് കടന്നു വന്നു ഉടൻ രാമുവിന്റെ ഭാര്യ വീട്ടിനുള്ളിലേക്ക് ഓടിപ്പോയി. പിന്നീടൊരിക്കൽ ഈ സംഭവത്തെക്കുറിച്ച് ചോദിച്ചപ്പോൾ, സാധാരണയായി ഭർതൃ പിതാവും മരുമകളും തമ്മിൽ ഒരുമിച്ച് ഒരു സ്ഥലത്ത് പാടില്ല എന്നുള്ളത് അവരുടെ ഒരു കീഴ്വഴക്കമാണെന്ന് രാമു മറുപടി പറയുന്നു. ഇത് ഏത് തരത്തിലുള്ള പ്രാക്ടീസിനെയാണ് സൂചിപ്പിക്കുന്നത്.

1

- a. Joking relationship
- b. Avunculate
- c. Amitate
- d. Avoidance

5 You are watching the cricket match between India and West Indias on TV. An Indian batsman scored a century. You feel so glad. What term can be used to refer to your feeling

ഇന്ത്യയും വെസ്റ്റിന്റീസും തമ്മിലുള്ള ക്രിക്കറ്റ് മത്സരം ടി. വി. യിലൂടെ കാണുകയാണ് നിങ്ങൾ എന്ന് സങ്കല്പിക്കുക.. ഒരു ഇന്ത്യൻ ബാറ്റ്സ്മാൻ സെഞ്ചൂറിനേടുമ്പോൾ സ്വാഭാവികമായും നിങ്ങൾക്ക് ആഹ്ലാദം തോന്നുന്നു. നിങ്ങളുടെ ഈ വികാരത്തെ ഏത് വാക്കിലൂടെ വിശേഷിപ്പിക്കാം

1

- a. Communalism
- b. Nationalism

- c. Nationality
- d. Anti nationalism

6. John and his family were living in a village. His brother Sunil got a reputed job in a far away city. After a few years the whole family shifted their residence to the newly hired flat in the city where Sunil was working. They purchased a car on loan and their life pattern changed much. Identify the process involved.

ജോണും കുടുംബവും ഒരു ഗ്രാമത്തിലാണ് വസിച്ചിരുന്നത്. ജോണിന്റെ സഹോദരൻ സുനിലിന് ദൂരെയുള്ള ഒരു പട്ടണത്തിൽ മെച്ചപ്പെട്ട ഒരു ജോലി ലഭിച്ചപ്പോൾ അവർ പട്ടണത്തിൽ ഒരു ഫ്ലാറ്റ് വാങ്ങുകയും കുടുംബം മുഴുവനായി താമസം അങ്ങോട്ടേക്ക് മാറ്റുകയും ചെയ്തു. ഇവിടെ നടന്ന പ്രക്രിയ എന്താണ്.

1

- a. Industrialization
- b. Sanskritisation
- c. Urbanization
- d. Colonisation

7. Certain lower caste communities in Kerala have limited the food patterns and certain aspects of the costumes of higher castes. These lower castes also have changed their caste name as equivalent to that of the higher castes. What is the appropriate term to refer this process.

കേരളത്തിൽ താഴ്ന്ന ജാതിയിൽപ്പെടുന്ന ചില വിഭാഗങ്ങൾ ചില ഉയർന്ന ജാതിക്കാരുടെ ഭക്ഷണ രീതിയും പാരമ്പര്യങ്ങളുടെ ചില വശങ്ങളും അനുകരിക്കുകയും ചെയ്തിട്ടുണ്ട് ഇതിൽ ചില വിഭാഗങ്ങൾ തങ്ങളുടെ ജാതിപ്പേര് പോലും ഉയർന്ന ജാതികൾക്ക് തുല്യമാക്കി മാറ്റിയുട്ടുണ്ട്. ഈ പ്രക്രിയയെ വിശേഷിപ്പിക്കുന്നത് എങ്ങനെ?

- a. Sanskritisation
- b. Modernisation
- c. Westernisation
- d. Acculturation

8. A boy often tells lie. Teachers and parents advised him to many times. Still he continues the behaviour. Identify the act of the boy.

സ്ഥിരമായി കള്ളം പറയുന്ന ശീലമുള്ള ഒരു കുട്ടി അധ്യാപകരും മാതാപിതാക്കളും എത്രതവണ ഉദ്ദേശിച്ചിട്ടും നേരെയാവുന്നില്ല. ഇത്തരം സ്വഭാവത്തെ എങ്ങനെ വിശേഷിപ്പിക്കാം.

1

- a. Crime
- b. Illiteracy
- c. Juvenile delinquency
- d. Alcoholism

9. Match the following suitably

A	B	C
Brahma Samaj	C.K Janu	Decentralisation
Arya Samaj	Kabir	Land alienation
Adivasi mahasabha	Gandhiji	Oneness of God
Grama Swaraj	Dayananda Saraswathy	Against Sati
Bakti movement	Ram Mohan Roy	Back to Vedas

5

10 Point out the types and degrees of Kinship in the following diagram

താഴെ തന്നിരിക്കുന്ന ഡയഗ്രാമിൽ കിൻഷിപ്പിന്റെ തരവും ഡിഗ്രിയും അടയാളപ്പെടുത്തുക

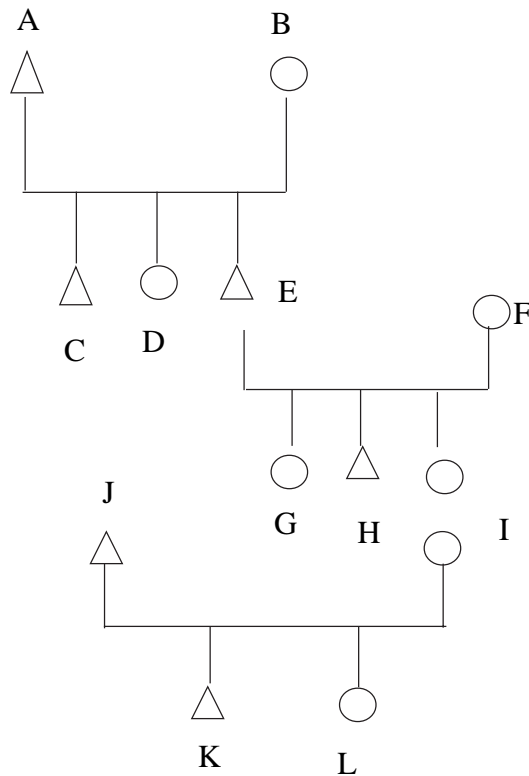

Hints

1. Consanguineous
2. Affinal
3. Primary
4. Secondary
5. Tertiary

3

11. Of the following which one is the most important factor for high population growth in India

തന്നിരിക്കുന്നതിൽ ഇന്ത്യയുടെ ജനസംഖ്യാ വർദ്ധനവിന് കാരണമാകുന്ന പ്രധാന ഘടകം ഏതാണ്? നിങ്ങൾ തെരഞ്ഞെടുത്ത ഉത്തരത്തിനുള്ള ന്യായീകരണം എന്ത്?

- a. High fertility rate
- b. Low mortality rate
- c. Low morbidity rate
- d. Medical advancement

Give reasons to substantiate your choice

1

12



There are several similar advertisements which use women as a model. Do such advertisements affect the states of women. Assess in the light of the role of media in perpetuating gender discrimination.

സ്ത്രീകളെ ഒരു ഉപാധിയായി ഉപയോഗിച്ചുകൊണ്ട് അനേകം പരസ്യങ്ങൾ വിവിധ മാധ്യമങ്ങളിൽ പ്രത്യക്ഷപ്പെടുന്നുണ്ട്. ഇത്തരം പരസ്യങ്ങൾ സമൂഹത്തിൽ സ്ത്രീകളുടെ പദവിയെ ഏതെങ്കിലും വിധത്തിൽ സ്വാധീനിക്കുന്നുണ്ടോ? സമൂഹത്തിൽ ലിംഗപരമായ വേർതിരിവ് നിലനിർത്തുന്നതിൽ മാധ്യമങ്ങളുടെ പങ്കിന്റെ അടിസ്ഥാനത്തിൽ വിശകലനം ചെയ്യുക (5)

OR

Analyse the picture in the light of gender issues in your society (5)

നിങ്ങളുടെ സമൂഹത്തിൽ നിലനിൽക്കുന്ന സ്ത്രീ - പുരുഷ വേർതിരിവിന്റെ അടിസ്ഥാനത്തിൽ



തന്നിരിക്കുന്ന ചിത്രത്തിന് ഒരു വിശകലനക്കുറിപ്പ് തയ്യാറാക്കുക.

- 13. Kerala and Tamil Nadu experience a conflict in the matter of Kaveri river water issue. Marad issue is another conflict between two groups of people. Do you find any difference between these two conflicts. What is your suggestion to overcome such conflicts

കാവേരി നദീജലം സംബന്ധിച്ച് കേരളവും തമിഴ്നാടും തമ്മിൽ തർക്കം നിലനിൽക്കുന്നു. മാറാട് നടന്നത് രണ്ട് വിഭാഗങ്ങൾ തമ്മിലുള്ള മറ്റൊരു സംഘർഷമാണ്. രണ്ട് തർക്കങ്ങളും തമ്മിൽ എന്തെങ്കിലും വ്യത്യാസം കാണുന്നുണ്ടോ. ഇത്തരം സംഘർഷങ്ങൾ ലഘൂകരിക്കാൻ നിങ്ങളുടെ നിർദ്ദേശങ്ങൾ എന്തെല്ലാം.

Hint

Hurdles to national integratoin - Regionalism and communalism.

5

സൂചന ദേശീയോദ്ഗ്രഥനത്തിനുള്ള വെല്ലുവിളികൾ

പ്രാദേശിക വാദവും വർഗ്ഗീയതയും

- 14 Read the following matrimonial advertisements

Nair groom 30/182. working Branch Manager, fair, athletic, issueless divorcee. Own flat and car in Mumbai No dowry

Fair handsome Nair boy 34 /174, Thriketta (Sudhajathakam), working in Dubai, seeks alliences from qualified Nair girls with biodata and horoscope.

By analysing the advertisements, do you find any difference from the conventional form of marriage. How does this change reflect in the institutions of marriage and family. 6

പത്രമാധ്യമത്തിൽ വന്ന വിവാഹപ്പരസ്യങ്ങളാണ് നൽകിയിരിക്കുന്നത്. ഈ പരസ്യങ്ങൾ വിശകലനം ചെയ്യുമ്പോൾ നമ്മുടെ സമൂഹത്തിൽ പരമ്പരാഗതമായി കണ്ടുവരുന്ന വിവാഹരീതിയിൽ നിന്ന് എന്തെങ്കിലും വ്യത്യാസം കാണുന്നുണ്ടോ? ഈ വ്യത്യാസം എപ്രകാരമാണ് ആധുനിക കുടുംബ വ്യവസ്ഥകളിൽ പ്രതിഫലിക്കുന്നത്.

- 15 In Perumatti Panchayat in the Palakkad district people (organised to) agitate against the over exploitation of underground water by a multinational bevarages company. Analyse the agitation in the light of social movements.

പാലക്കാട് ജില്ലയിലെ പെരുമാട്ടി പഞ്ചായത്തിൽ ഒരു ബിവറേജസ് കമ്പനി അമിതമായി ഭൂഗർഭ ജലം ചൂഷണം ചെയ്തതിനെതിരെ ജനങ്ങൾ സംഘടിച്ച് സമരം ചെയ്തു. ഈ സമരത്തെ സോഷ്യൽ മൂവ്മെന്റിന്റെ പശ്ചാത്തലത്തിൽ വിശകലനം ചെയ്യുക.

2

Hints

- 1. Collective consciousness
- 2. Deliberate effort

3. Desirable change or resist change

16 Classify the following into factors of high population and low population.

education, poverty, low fertility, illiteracy, technological advancement, high mortality rate, malnutrition, traditional occupation, health and hygiene

State the logic behind your classification 3

തന്നിരിക്കുന്നവയെ ഉയർന്ന ജനസംഖ്യാനിരക്കിനും താഴ്ന്ന ജനസംഖ്യാനിരക്കിനും കാരണമായ ഘടകങ്ങളായി തരം തിരിക്കുക. നിങ്ങളുടെ തരം തിരിവിനു പിന്നിലെ യുക്തി എന്താണെന്ന് വിശദമാക്കുക.

17 Given under are certain agitations that emerged in Kerala against the practices associated with caste system.

തന്നിരിക്കുന്നവ ജാതിവ്യവസ്ഥിതിയുമായി ബന്ധപ്പെട്ട ചില അനാചാരങ്ങൾക്കെതിരെ നടന്ന സമരങ്ങളാണ്. ഇന്ന് കേരളത്തിൽ ഇത്തരത്തിൽ സമരങ്ങൾ അനിവാര്യമാകുന്ന അവസ്ഥ നിലവിലുണ്ടോ?

ഇന്നത്തെ ഇന്ത്യൻ സമൂഹത്തിൽ ജാതി സംഘടനകളുടെ പങ്ക് എന്താണ്.

Kallumala agitation

Villuvandi samaram

Mappila samaram

Arivippuram prathishta, etc.

a. Do you find any situation that requires such agitations in Kerala, today 2

b. What is the role of caste groups in the contemporary Indian society. 3

18 Suppose your father is an illiterate man and is working as an agricultural labourer. Imagine and point out the difficulties he will have to face in his day to day life. Do you think illiteracy is a social problem. Why? 5

നിങ്ങളുടെ അച്ഛൻ ഒരു നിരക്ഷരനായ കർഷകത്തൊഴിലാളിയാണെന്ന് സങ്കല്പിക്കുക. തന്റെ നിരക്ഷരതമൂലം അദ്ദേഹത്തിന് എന്തൊക്കെ പ്രശ്നങ്ങളായിരിക്കും അഭിമുഖീകരിക്കേണ്ടിവന്നിരിക്കുക. നിരക്ഷരത ഒരു സാമൂഹിക പ്രശ്നമാണോ? എന്തുകൊണ്ട്?

19 a. Classify the following activities performed by males and females in your house. 2

Cooking, newspaper reading, drawing water, earning livelihood, washing, decision making, looking after children, serving food,

തന്നിരിക്കുന്ന പ്രവർത്തനങ്ങളിൽ സ്ത്രീകളും പുരുഷന്മാരും ചെയ്യുന്നവ തരം തിരിക്കുക. ഇപ്രകാരം തരംതിരിക്കുമ്പോൾ സ്ത്രീകളുടെയും പുരുഷന്മാരുടേയും ഉത്തരവാദിത്വങ്ങൾ തമ്മിൽ എന്തെങ്കിലും അന്തരം കാണുന്നുണ്ടോ?

ഈ അന്തരം സ്ത്രീകളുടെയും പുരുഷന്മാരുടെയും പദവിയിൽ എങ്ങനെ പ്രതിഫലിക്കുന്നു.

b. Is there any disparity in the nature of work performed by males and females 2

c. How does this disparity reflect in the status of males and females

4

20 Suppose you are living in a village. The Tata Iron and Steel company wants to set up their branch nearby your house. It will definitely bring about certain changes in your village. Imagine, point out and evaluate the changes that may happen to your village after a few years.

നിങ്ങൾ ഒരു ഗ്രാമവാസിയാണെന്ന് സങ്കൽപ്പിക്കുക. നിങ്ങളുടെ വീടിന് സമീപം റാറ്റാ സ്റ്റീൽ കമ്പനിയുടെ ഒരു ശാഖ പ്രവർത്തനമാരംഭിക്കുകയാണെങ്കിൽ കാലക്രമേണ നിങ്ങളുടെ ഗ്രാമത്തിൽ ചില മാറ്റങ്ങൾ ദൃശ്യമാകുമല്ലോ. എന്തൊക്കെ മാറ്റങ്ങളാവും ഉണ്ടാവുക. അവയുടെ സ്വീകാര്യത പരിശോധിക്കുക

8

Hints

1. Density of population
2. Economic changes
3. social heterogeneity
4. Problems of vices

21 The following diagram shows the decadal growth of Indian population

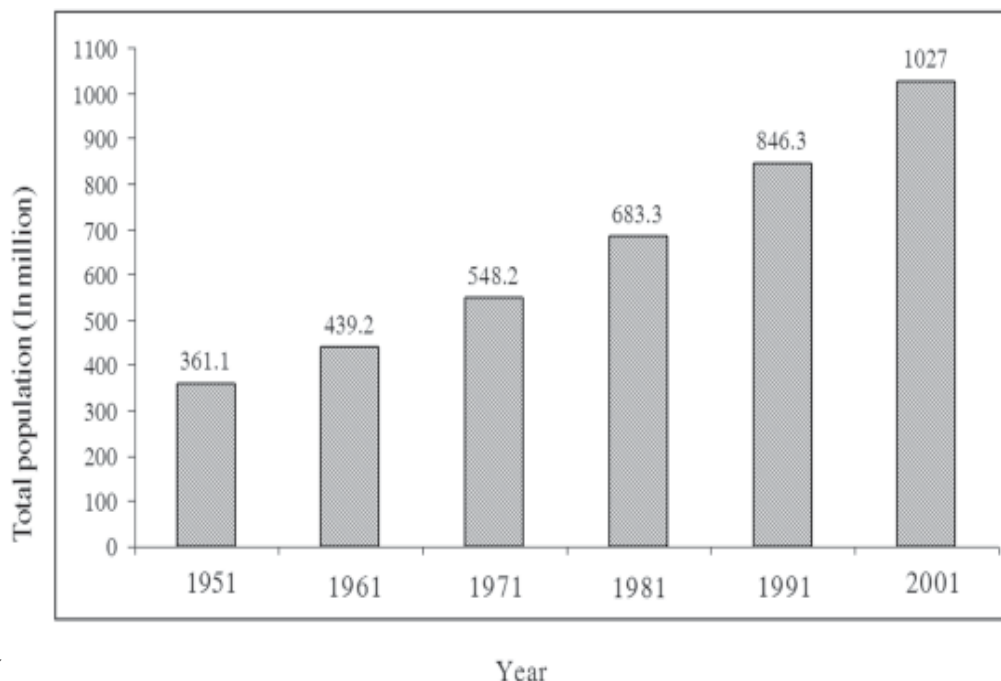

Ev after year. Do you think this is due to the defects in our policy. Suggest some measures for the successful implementation of population policy in your panchayat.

8

കഴിഞ്ഞ ഏതാനും ദശാബ്ദങ്ങളായുള്ള ഇന്ത്യയുടെ ജനസംഖ്യാവളർച്ചയാണ് ഡയഗ്രത്തിൽ

കാണിച്ചിരിക്കുന്നത്. നമ്മുടെ ജനസംഖ്യാനയം ജനസംഖ്യാനിയന്ത്രണത്തിന് പ്രത്യേക ഊന്നൽ നൽകുന്നുണ്ടെങ്കിലും അത് ഫലവത്തായി കാണുന്നില്ല. ഇത് നയത്തിന്റെ വൈകല്യമാണോ. നിങ്ങളുടെ പഞ്ചായത്തിൽ ജനസംഖ്യാനയം ഫലപ്രദമായി പ്രാവർത്തികമാക്കുന്നതിനുള്ള മാർഗ്ഗ നിർദ്ദേശം നൽകുക.

OR

a Ramu belonging to a scheduled caste and Balu belonging to an upper caste applied for a job. Even though Ramu's qualification was lower than that of Balu, he got the job. This was due to the policy of reservation. Do you favour such a situation.

b. Substantiate your answer by identifying the backward classes in your village and analysing their socio - economic conditions

8

a പട്ടിക ജാതിയിൽ പെടുന്ന രാമുവും ഉയർന്ന ജാതിയിൽപെടുന്ന ബാലുവും ഒരു ജോലി ക്കായി അപേക്ഷിച്ചു. സംവരണത്തിന്റെ അനുകൂല്യത്തിൽ, രാമുവിന്റെ യോഗ്യത ബാലുവിനേക്കാൾ താഴെയാണെങ്കിൽ പോലും രാമുവിന് ജോലി ലഭിച്ചു. ഇതിനെ നിങ്ങൾ അനുകൂലിക്കുന്നുണ്ടോ.

b. നിങ്ങളുടെ ഗ്രാമത്തിലെ പിന്നോക്കവിഭാഗങ്ങളും സാമൂഹികവും സാമ്പത്തികവുമായ സ്ഥിതി വിശകലനം ചെയ്ത് നിങ്ങളുടെ ഉത്തരത്തിന് സാധൂകരണം നൽകുക.

SCORING INDICATORS

Qn. No.	Scoring Indicators	Score	Total Score																		
1	linguistic diversity	1	1																		
2	It was an urban civilization	1	1																		
3	Vanaprastha	1	1																		
4	Avoidance	1	1																		
5	Nationalism	1	1																		
6	Urbanization	1	1																		
7	Sanskritisation	1	1																		
8	Juvenile delinquency	1	1																		
9	<table border="1" style="width: 100%; border-collapse: collapse;"> <thead> <tr> <th style="width: 33%;">A</th> <th style="width: 33%;">B</th> <th style="width: 33%;">C</th> </tr> </thead> <tbody> <tr> <td>Brahmo</td> <td>Ram mohan Roy</td> <td>Against Sati</td> </tr> <tr> <td>Arya Samaj</td> <td>Dayananda Saraswathy</td> <td>Back to Vedas</td> </tr> <tr> <td>Adivasi mahasabha</td> <td>C.K Janu</td> <td>Land alienation</td> </tr> <tr> <td>Grama swaraj</td> <td>Gandhiji</td> <td>Decentralisation</td> </tr> <tr> <td>Bakti movement</td> <td>kabir</td> <td>Oneness of God</td> </tr> </tbody> </table>	A	B	C	Brahmo	Ram mohan Roy	Against Sati	Arya Samaj	Dayananda Saraswathy	Back to Vedas	Adivasi mahasabha	C.K Janu	Land alienation	Grama swaraj	Gandhiji	Decentralisation	Bakti movement	kabir	Oneness of God	1 1 1 1 1	5
A	B	C																			
Brahmo	Ram mohan Roy	Against Sati																			
Arya Samaj	Dayananda Saraswathy	Back to Vedas																			
Adivasi mahasabha	C.K Janu	Land alienation																			
Grama swaraj	Gandhiji	Decentralisation																			
Bakti movement	kabir	Oneness of God																			
10	Consanguinous = A and C/ any correct points Affinal = A and B/ any correct points Primary = A & B / A & C/ any other correct points Secondary = A & G / any other correct relationship Tertiary = A & K / any other correct answer Marking in the diagram	$\frac{1}{2}$ $\frac{1}{2}$ $\frac{1}{2}$ $\frac{1}{2}$ $\frac{1}{2}$ $\frac{1}{2}$	3																		
11	i) High fertility rate ii) Relevance of substantiating points	1 2	3																		
12	i) such advertisement affect the status of women ii) Analysis of such advertisements iii) Media standardised and stereotyped patriarchal norms and values / any other relevant answer OR i) Identification of gender roles ii) Differentiating gender roles iii) Impact of these role differences on the status	1 2 2 2 1 2	5 5																		
13	i) Kaveri issue is a regional dispute whereas Marad issue is a communal clash ii) Difference between regionalism and communication	1 2																			

Qn. No.	Scoring Indicators	Score	Total Score
	iii) Relationship between role and status	2	
	iv) Reasons for the low status of women	2	8
20	i) Ability to visualise the situation ii) Identification of areas of change iii) Change in the density of population iv) Major economic changes v) Change in heterogeneity of area vi) vices that may arise vii) Desirability of these changes	1 2 1 1 1 1 1	8
21	i) A brief analysis of the table ii) Recognise that population growth is not the problem with the policy but with its implementation iii) Suggestions for the successful implementation of the policy (atleast 6)	2 2 4	8
	OR		
	i) Whether agree or disagree ii) Identifies the backward communities iii) Analyses their socio economic position iv) Justifies the answer on the basis of the analysis	1 2 3 2	8

* Score and split score given in bracket is the score for the questions of internal choice

QUESTION WISE ANALYSIS

Q. No	CO	Mental Process	Type of Questions	Score	Time (Mts)
1	6	2,3,7	Objective	1	3
2	7	1,6,7	Objective	1	3
3	9	1,2,5	Objective	1	4
4	22	2,5,7	Objective	1	3
5	54,55	3,7	Objective	1	3
6	15,41	1,2,3,7	Objective	1	4
7	42	1,2,3,7	Objective	1	3
8	48	5	Objective	1	3
9	10,31,32,34	4,6	Objective	5	7
10	21	1,5,8	SQ	3	6
11	37,38	1,6,7	Objective	3	5
12	51,52	2,5,10	SQ	5	11
13	51,53	5,6,8,9	SQ	(5)	(11)
14	54,55	2,6,10	SQ	5	10
15	16,20	2,3,5,9	SQ	6	11
16	31,33	2,7	SQ	6	9
17	36,37,38	4,6,9,10	SQ	5	7
18	25,26	2,5,7,10	SQ	5	13
19	45,46	2,6,9	SQ	5	7
20	50,51	3,4,10	Essay	8	13
21	40,41	6,7,9,10	Essay	8	12
22	37,39	8,9,10	Essay	8	12
23	27,28,29	5,9,10	Essay	(8)	(12)